

TABLE OF CONTENTS

Model SPC-4 4-Row Stalk Puller / Chopper & Model SPC-6 6-Row Stalk Puller / Chopper

1st Edition

CAT223

Beginning Serial #390000

<u>Section</u>	<u>Page</u>
SPC-4 4-Row Frame & Shields.....	3
SPC-4 4-Row Drives.....	5
SPC-4 4-Row Rotor Assembly.....	7
SPC-6 6-Row Frame & Shields.....	9
SPC-6 6-Row Drives.....	11
SPC-6 6-Row Rotor Assembly.....	13
Wheel Puller Unit.....	15
Decals.....	17
Warranty	

NOTES

The Terms "Left" and "Right" used in the description of parts are determined by facing the direction of travel of the machine.

"A/R" found in the "Qty. Req'd" column denotes "As Required".

"OPT" found in the "Qty. Req'd" column denotes "Optional".

1100 Holland Road Suffolk, VA 23434 U.S.A.
(757) 539-0231 / Fax - (757) 934-3264

1701 S. Slappey Blvd./P.O. Box 3687 Albany, GA 31706
(229) 439-2217 / Fax (229) 439-9343

AMADAS
INDUSTRIES

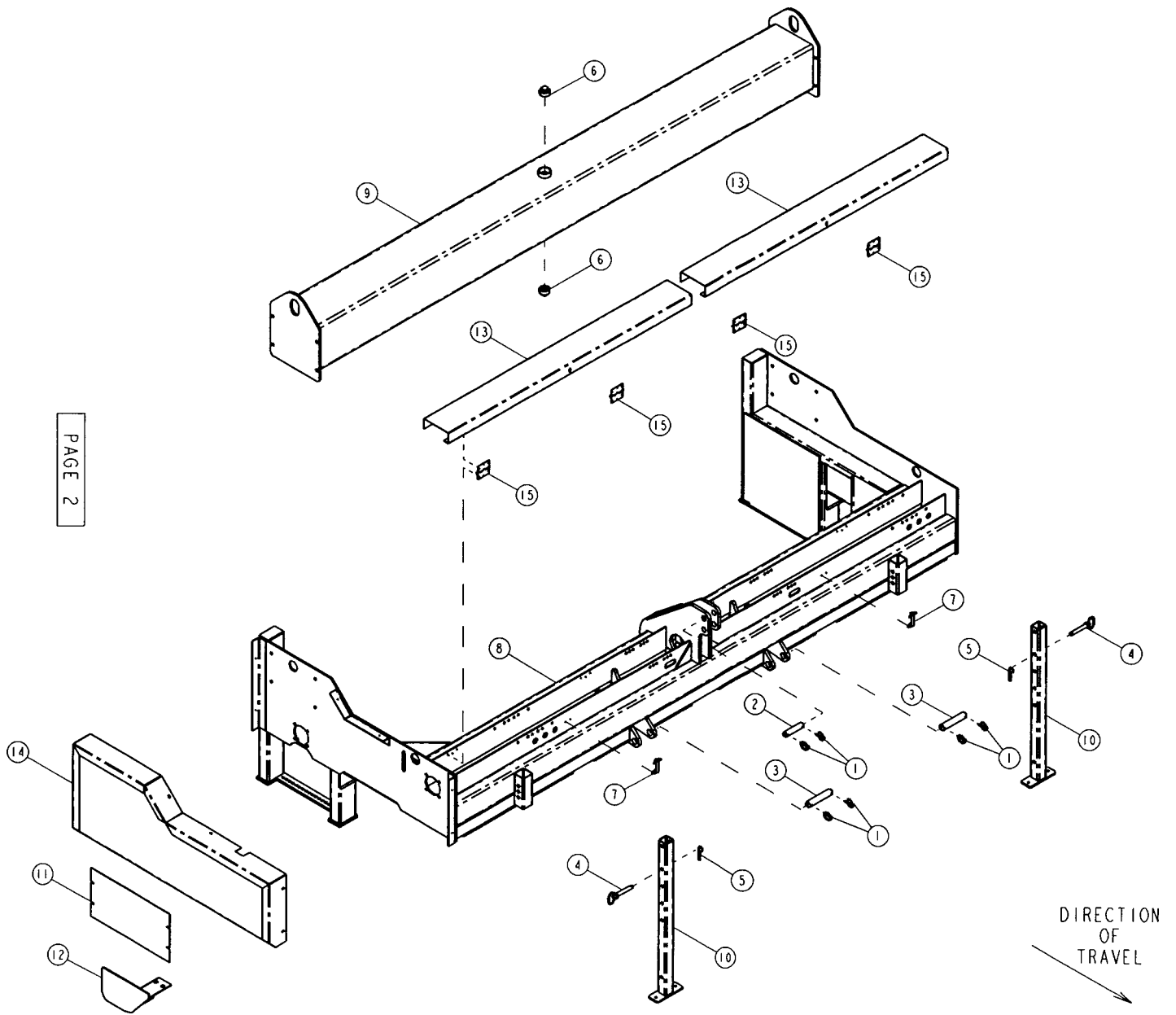

SPC-4 4-ROW FRAME & SHIELDS

ITEM	PART NUMBER	DESCRIPTION	QTY SHOWN	QTY REQ'D	COMMENTS
1	1465		6		
2	1782		1		
3	1783		2		
4	2056	PIN, HITCH; 3/4 DIA. X 4-3/4 LONG	2		
5	2196	PIN, PLATED HAIR COTTER; 3-9/16 X .178	2		
6	2515	PLUG, 2" MALE PIPE; GALV.	2		
7	7024	HOOK, SPRING LOADED; 90 DEGREE	2		
8	93594	FRAME, SPC-4	1		
9	93595	BOX, WEIGHT	1		
10	93608	LEG, SUPPORT	2		
11	126636	SHIELD, LOWER; PULLER/CHOPPER	1		
12	126660	SHIELD, LOWER CHAIN	1		
13	126661	SHIELD, GEARBOX & DRIVELINE	2		
14	127150	SHIELD, DRIVES	1		
15	12935M	HINGE, 3-1/2 INCH	4		

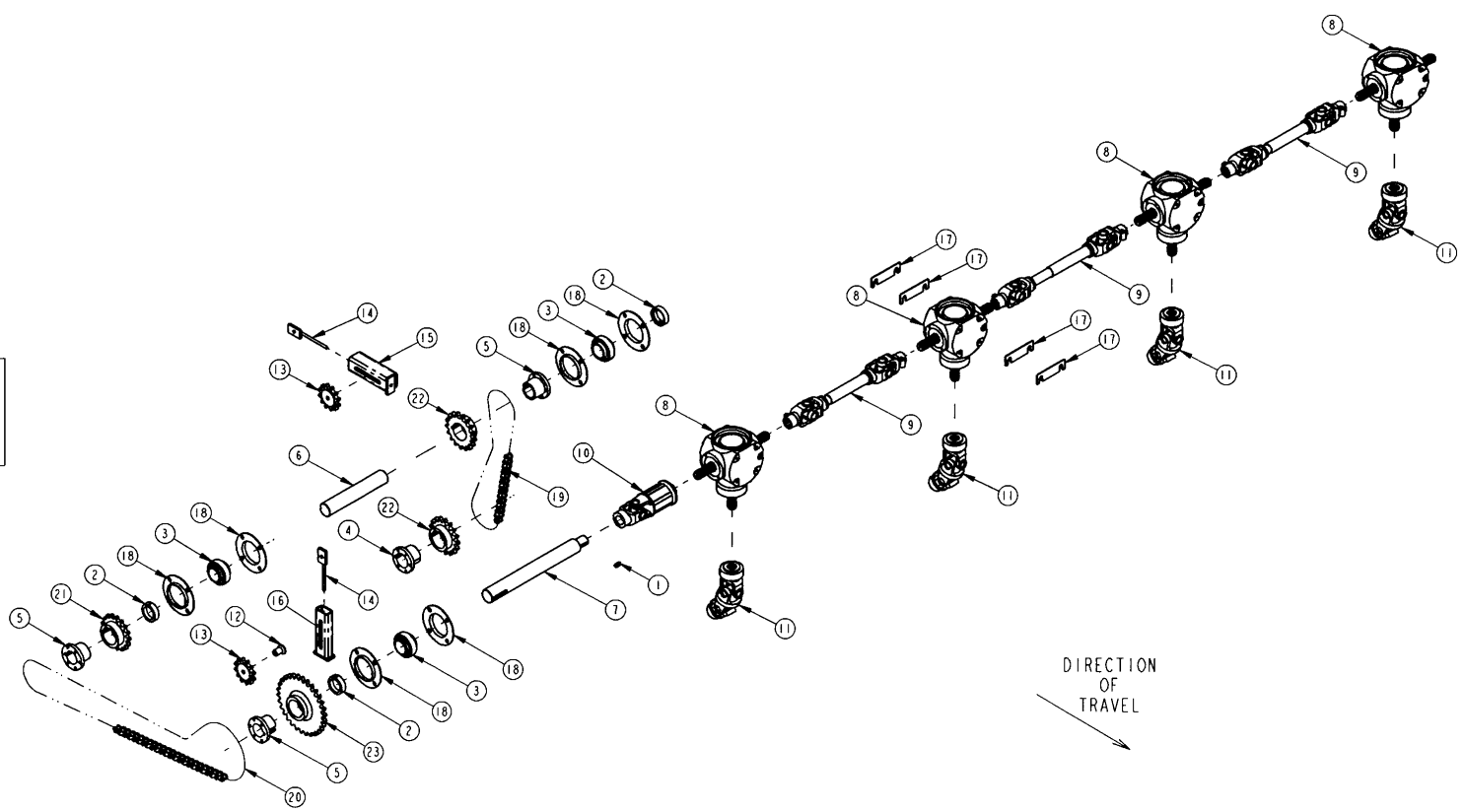

SPC-4 4-ROW DRIVES

ITEM	PART NUMBER	DESCRIPTION	QTY SHOWN	QTY REQ'D	COMMENTS
1	1191	KEY, 3/8 X 1	1		
2	3087	COLLAR, 2-3/16 ECCENTRIC LOCKING	3		INCLUDED WITH BEARING
3	3148	INSERT, 2-3/16 NON-RELUB. BRG;E	3		
4	5663	BUSHING, O1 2-7/16	1		
5	5691	BUSHING, O1 - 2-3/16	3		
6	10750	SHAFT, JACK	1		
7	10751	SHAFT, MAIN DRIVE; 36" ROW	1		--SEE NOTE 1--
8	11343	GEARBOX, 2050 1:1 1-3/8-6 TEE B	4		
9	11344	PTO, 1-3/8 - 6 SIZE 4 QD 450MM CTOC	3		--SEE NOTE 2--
10	11346	CLUTCH, RATCHET; SIZE 4	1		
11	11369	JOINT, DBL U 1-3/8-6X1-3/8-6 RS, SIZE 4	4		--SEE NOTE 3--
12	20592	STANDOFF, 5/8 BORE X 1-1/2 LONG	1		
13	51405	IDLER, 80A12, 5/8 BORE	2		
14	61563	ADJUSTER, SCREW; 5/8-11; 3/8-16	2		
15	61564	ADJUSTER, CHAIN	1		
16	61756	ADJUSTER, CHAIN	1		
17	124869	SHIM, GEARBOX MOUNT	4	16	
18	3108-1	FLANGETTE, 100MSZP FOR 2-3/16" BRG; ZINC PLATED	6		
19	4365D-62	CHAIN, NO.80 DIAMOND, 61 PITCHES+CONNECTOR	1		4365D, CHAIN BY FT; 4360DB, CONNECTING LINK
20	4365D-106	CHAIN, NO.80 DIAMOND, 105 PITCHES+CONNECTOR	1		4365D, CHAIN BY FT; 4360DB, CONNECTING LINK
21	80Q17	SPROCKET, 80Q17	1		
22	80Q18	SPROCKET, 80Q18	2		
23	80Q30	SPROCKET, 80Q30	1		

-- NOTE 1--			
PART NO.	DESCRIPTION	QTY REQ'D	COMMENTS
10751	SHAFT, MAIN DRIVE; 36" ROW	1	SPC-4-36
10752	SHAFT, MAIN DRIVE; 38" ROW	1	SPC-4-38
10753	SHAFT, MAIN DRIVE; 40" ROW	1	SPC-4-40
-- NOTE 2 -- PTO COMPONENTS--			
11344A	KIT, CROSS & BEARING; SIZE 4	2	
11344B	YOKE, 1-3/8 6-SPLINE SIZE 4 PIN DISCONNECT	2	
11344C	YOKE, INNER, W/MALE TUBE	1	
11344D	YOKE, INNER, W/FEMALE TUBE	1	
--NOTE 3 -- U-JOINT COMPONENTS--			
11344A	KIT, CROSS & BEARING; SIZE 4	2	
11345B	YOKE, 1-3/8 6-SPLINE	1	
11345C	JOINT, MIDDLE/DOUBLE UNIVERSAL	1	
11369A	YOKE, 1-3/8 6-SPLINE RS	1	

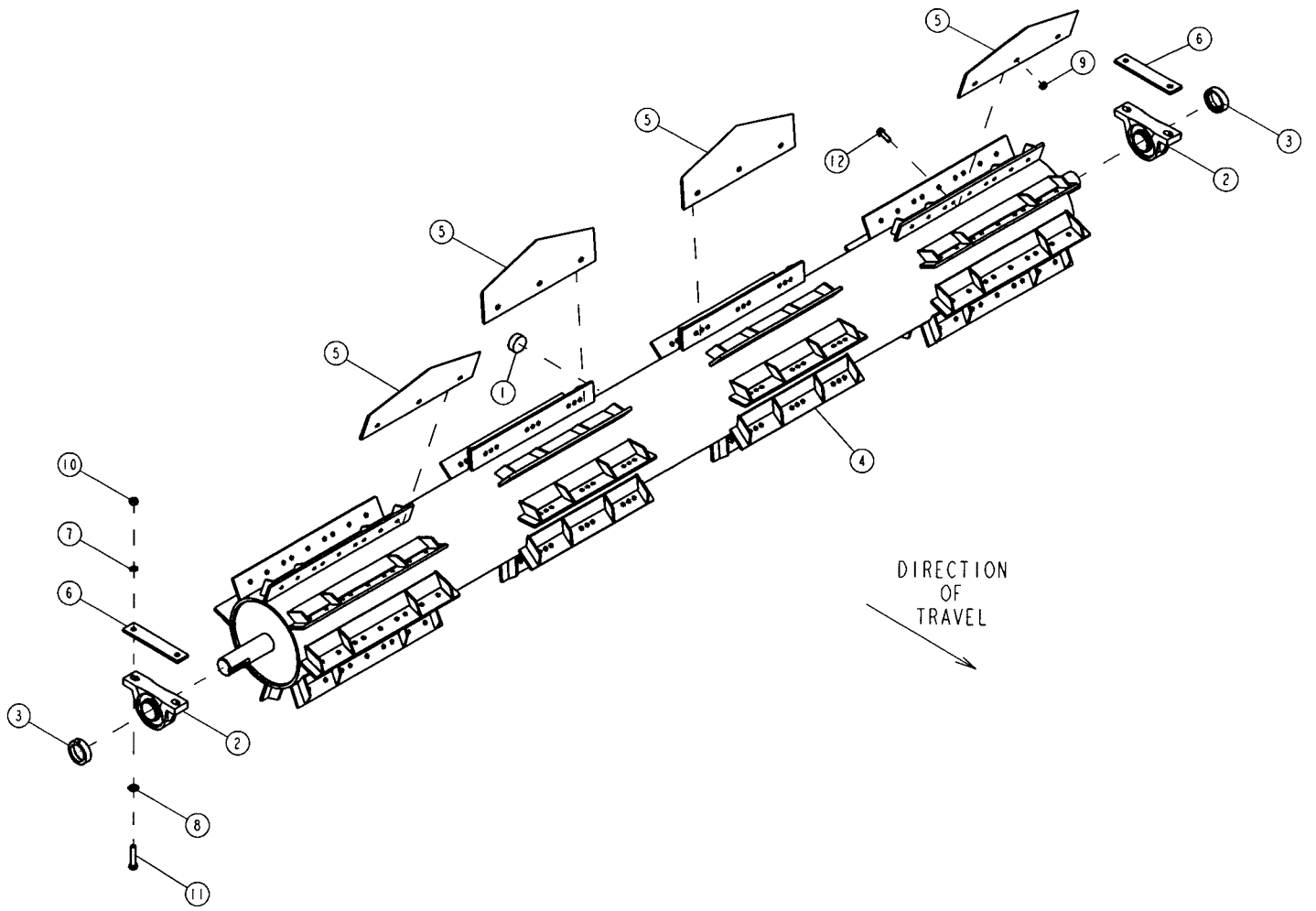

SPC-4 4-ROW ROTOR ASSEMBLY

ITEM	PART NUMBER	DESCRIPTION	QTY SHOWN	QTY REQ'D	COMMENTS
1	2515	PLUG, 2" MALE PIPE; GALV.	1		
2	3124	BEARING, 2-7/16 PILLOW BLOCK	2		
3	3125	COLLAR, 2-7/16 ECCENTRIC LOCKING	2		INCLUDED WITH BEARING
4	51517	ROTOR, STALK PULLER/CHOPPER; 4 ROW	1		--SEE NOTE 1--
5	61517	BLADE, 8" ANGLED	4	32	
6	93759	PLATE, BEARING; SPC-4	2		
7	G121574	LOCKWASHER, 5/8	1	4	
8	G131016	WASHER, 5/8 SAE FLAT	1	4	
9	G121200-8	NUT, 1/2-13 DEF. HEAD FLANGE; GRADE 8	1	96	
10	G121358-8	NUT, 5/8-18 SAE; GRADE 8	1	4	
11	G271752-8	SCREW, 5/8-18 X 3 SAE CAP; GRADE 8	1	4	
12	G451800-8	SCREW, 1/2-13 X 1-1/2 FLANGEHEAD CAP, GR 8	1	96	

-- NOTE 1 --		
PART NUMBER	DESCRIPTION	COMMENTS
51517	ROTOR, STALK PULLER/CHOPPER; 4 ROW	SERIAL NO. 390000 - 400199
51609	ROTOR, SPC-4; NON-GUSSETED	BEGINNING SERIAL NO. 400200

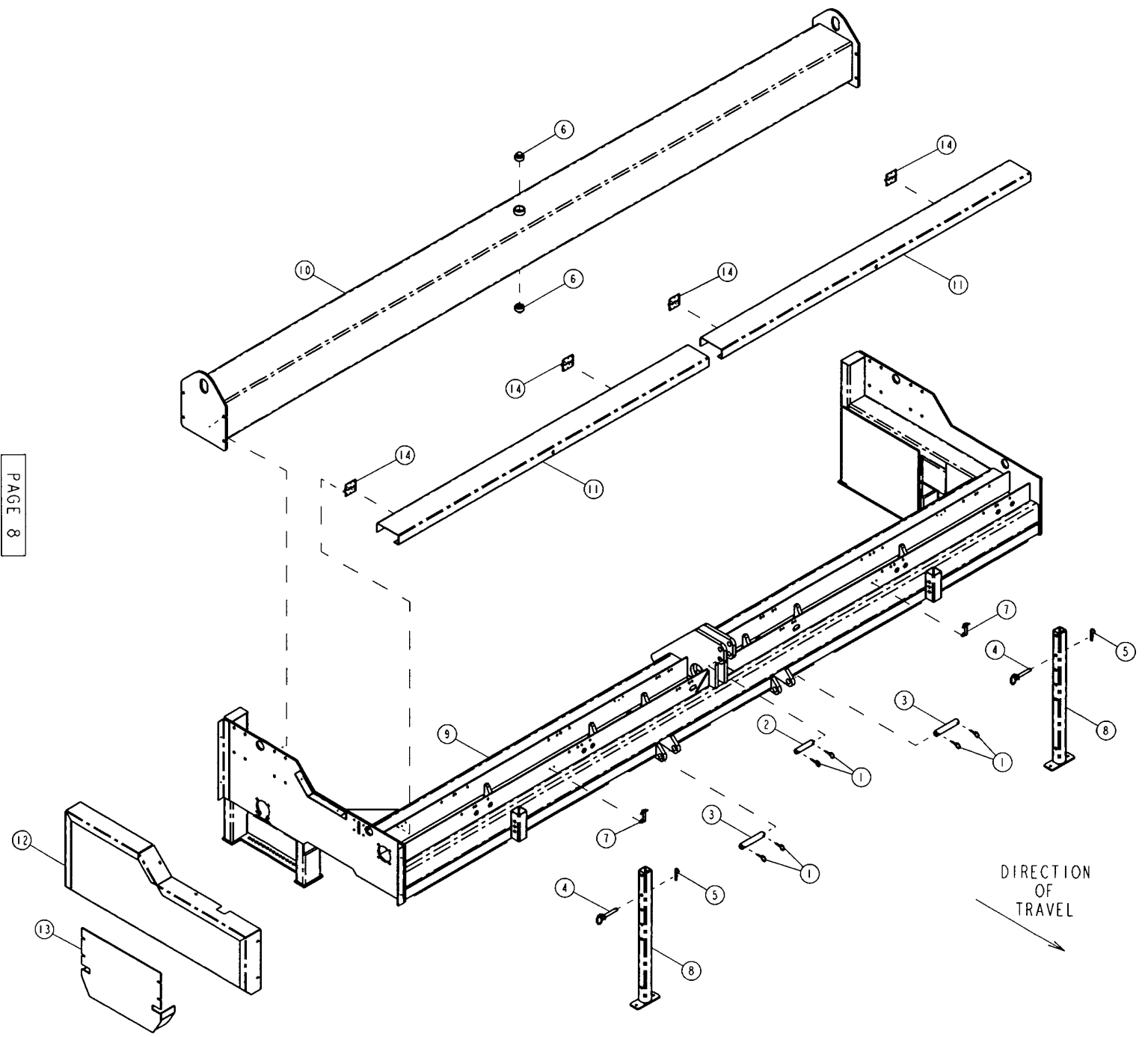

SPC-6 6-ROW FRAME & SHIELDS

ITEM	PART NUMBER	DESCRIPTION	QTY SHOWN	QTY REQ'D	COMMENTS
1	1400	PIN, LYNCH, 1/4" STANDARD	6		
2	1814	PIN, UPPER HITCH	1		
3	1815	PIN, LOWER HITCH	2		
4	2056	PIN, HITCH; 3/4 DIA. X 4-3/4 LONG	2		
5	2196	PIN, PLATED HAIR COTTER; 3-9/16 X .178	2		
6	2515	PLUG, 2" MALE PIPE; GALV.	2		
7	7024	HOOK, SPRING LOADED; 90 DEGREE	2		
8	93608	LEG, SUPPORT	2		
9	93652	FRAME, SPC-6	1		
10	93688	BOX, WEIGHT; SPC-6	1		
11	127292	SHIELD, GEARBOX & DRIVELINE	2		
12	127321	SHIELD, DRIVES	1		
13	127370	SHIELD, LOWER; SPC-6	1		
14	12935M	HINGE, 3-1/2 INCH	4		

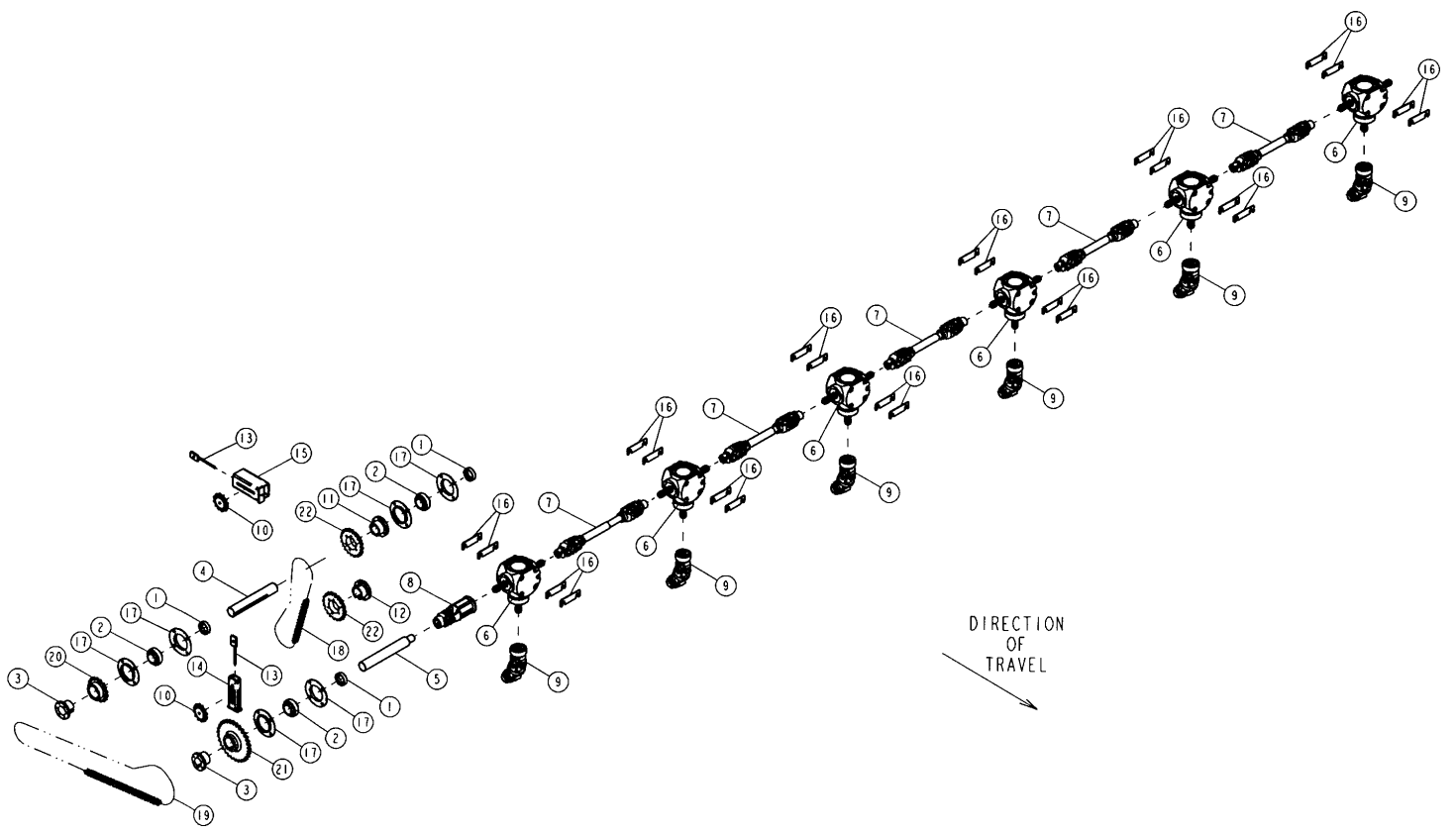

SPC-6 6-ROW DRIVES

ITEM	PART NUMBER	DESCRIPTION	QTY SHOWN	QTY REQ'D	COMMENTS
1	3087	COLLAR, 2-3/16 ECCENTRIC LOCKING	3		INCLUDED WITH BEARING
2	3148	INSERT, 2-3/16 NON-RELUB. BRG;E	3		
3	5691	BUSHING, OI - 2-3/16	2		
4	10822	SHAFT, JACK	1		
5	10827	SHAFT, MAIN DRIVE; 38" ROW, SPC-6	1		10751 SHAFT, MAIN DRIVE; 36" ROW
6	11343	GEARBOX, 2050 1:1 1-3/8-6 TEE B	6		
7	11344	PTO, 1-3/8 - 6 SIZE 4 QD 450MM CTOC	5		-- SEE NOTE 1 --
8	11346	CLUTCH, RATCHET; SIZE 4	1		
9	11369	JOINT, DBL U 1-3/8-6X1-3/8-6 RS, SIZE 4	6		-- SEE NOTE 2 --
10	51405	IDLER, 80A12, 5/8 BORE	2		
11	51584	BUSHING, SF 2-3/16	1		
12	51601	BUSHING, SF 2-7/16	1		
13	61563	ADJUSTER, SCREW; 5/8-11; 3/8-16	2		
14	61756	ADJUSTER, CHAIN	1		
15	61757	ADJUSTER, CHAIN	1		
16	124869	SHIM, GEARBOX MOUNT	24		
17	3108-1	FLANGETTE, 100MSZP FOR 2-3/16" BRG; ZINC PLATED	6		
18	4365D-64	CHAIN, NO. 80 DOMESTIC, 63 PITCHES+CONNECTOR	1		4365D, CHAIN BY FT; 4365DB, CONNECTING LINK
19	4365D-110	CHAIN, NO. 80 DOMESTIC, 109 PITCHES+CONNECTOR	1		4365D, CHAIN BY FT; 4365DB, CONNECTING LINK
20	80Q17	SPROCKET, 80Q17	1		
21	80Q30	SPROCKET, 80Q30	1		
22	80SF20	SPROCKET, 80SF20	2		

-- NOTE 1 -- PTO COMPONENTS --			
PART NO.	DESCRIPTION	QTY REQ'D	COMMENTS
11344A	KIT, CROSS & BEARING; SIZE 4	2	
11344B	YOKE, 1-3/8 6-SPLINE SIZE 4 PIN DISCONNECT	2	
11344C	YOKE, INNER, W/MALE TUBE	1	
11344D	YOKE, INNER, W/FEMALE TUBE	1	
-- NOTE 2 -- U-JOINT COMPONENTS --			
11344A	KIT, CROSS & BEARING; SIZE 4	2	
11345B	YOKE, 1-3/8 6-SPLINE	1	
11345C	JOINT, MIDDLE/DOUBLE UNIVERSAL	1	
11369A	YOKE, 1-3/8 6-SPLINE RS	1	

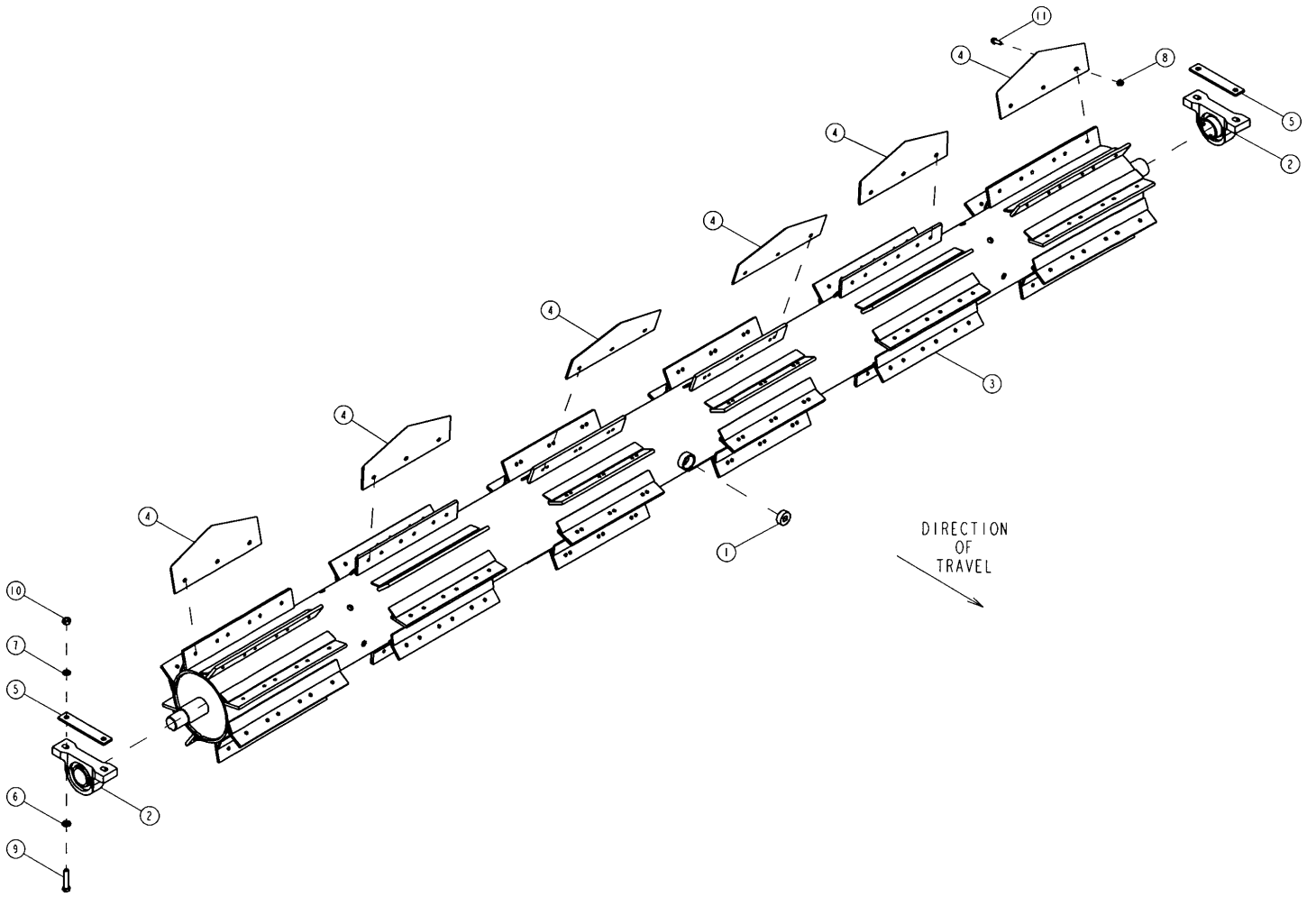

SPC-6 6-ROW ROTOR ASSEMBLY

ITEM	PART NUMBER	DESCRIPTION	QTY SHOWN	QTY REQ'D	COMMENTS
1	2515	PLUG, 2" MALE PIPE; GALV.	1		
2	3048	BEARING, 2-15/16 PILLOW BLOCK	2		
3	51598	ROTOR, SPC-6	1		
4	61517	BLADE, 8" ANGLED	6	48	
5	93758	PLATE, BEARING; SPC-6	2		
6	G131017	WASHER, 3/4 SAE FLAT	1	4	
7	G131046	LOCKWASHER, 3/4	1	4	
8	G121200-8	NUT, 1/2-13 DEF. HEAD FLANGE; GRADE 8	1	144	
9	G271799-8	SCREW, 3/4-16 X 3-1/2 SAE CAP GRADE 8	1	4	
10	G426099-8	NUT, 3/4-16 SAE; GRADE 8	1	4	
11	G451800-8	SCREW, 1/2-13 X 1-1/2 FLANGEHEAD CAP, GR 8	1	144	

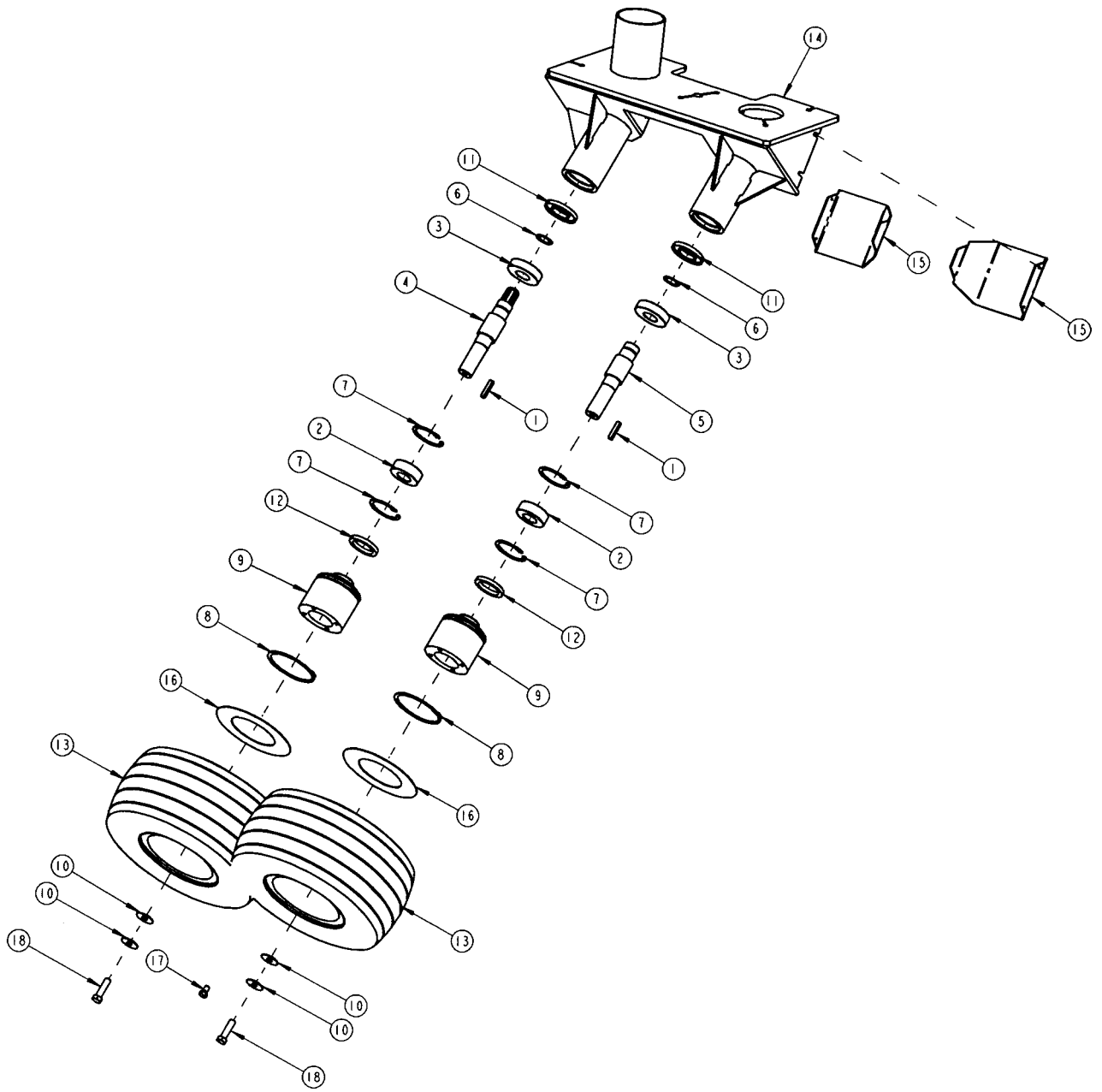

WHEEL PULLER UNIT

ITEM	PART NUMBER	DESCRIPTION	QTY SHOWN	QTY REQ'D	COMMENTS
1	1207	KEY, 3/8 X 2	2		
2	3240	BEARING, 80MM X 40MM X 28MM	2		
3	3241	BEARING, 90MM X 40MM X 23MM	2		
4	10792	SHAFT, DRIVE WHEEL	1		
5	10793	SHAFT, IDLER WHEEL	1		
6	20635	RING, 40MM EXT. RETAINING; 0.120 GROOVE	2		
7	20636	RING, 80MM INT. RET; .120 GRV	4		
8	20723	RING, EXTERNAL RETAINING; 5"	2	OPT	
9	51560	HUB, SPC	2		
10	70392	SPRING, BELLEVILLE DISC; 1-7/8 OD	4		
11	80329	SEAL, 90MM X 40MM X 10MM DOUBLE LIP	2		
12	80379	SEAL, 80MM X 60MM X 10MM TC	2		
13	80410	ASSEMBLY; W.T.&TUBE 4-PLY 18X9.5 SOFTRAC	2		
14	93342	HEAD, WHEEL PULLER UNIT; CSP02	1		
15	124882	SHIELD, U-JOINT	2		
16	127036	DISC, DIRT SHIELD	2	OPT	
17	80113E	BOLT, LUG	1	8	
18	6271547	SCREW, 5/8-11 X 1-1/2 USS CAP	2		

CAUTION

Do Not Operate this machine until you have read and understand the operators manual. If you do not have a copy of the operators manual contact your dealer or our factory Immediately.

Amadas Industries
1100 Holland Rd./Suffolk, VA
23434
757-539-0231

or

8191

1

WARNING

Do Not Operate
unless all Safety
Shields & Guards
are in place.

8547

2

CAUTION

- 1) Keep all shields in place while Machinery is in Operation.
- 2) Disengage Power before proceeding to adjust, lubricate, clean, unclog or otherwise work on machine unless unless specifically recommended in the Operator's Manual.
- 3) Wait for all motion to stop before servicing this machine
- 4) Keep Hands, Feet, and Clothing away from moving parts.
- 5) Keep off Equipment unless seat or platform for operation is provided.
- 6) Keep all others off.
- 7) Make certain everyone is clear of machine before starting.

8190

3

DECALS

ITEM	PART NUMBER	DESCRIPTION	QTY SHOWN	QTY REQ'D	COMMENTS
1	8191	DECAL, CAUTION: READ OPERATOR'S MANUAL	1		
2	8547	DECAL, DO NOT OPERATE WITHOUT SHIELDS	1	4	
3	8190	DECAL, "CAUTION" (LIST)	1		
THE FOLLOWING DECALS ARE USED BUT ARE NOT SHOWN					
	8343	DECAL, AMADAS "AMERICAN MADE"		1	
	80417	DECAL, SPC-4		2	
	80418	DECAL, "AMADAS"; 28-1/2"		2	
	8424	DECAL, 3M HONEYCOMB YELLOW REFLECTIVE		A/R	
	8425	DECAL, 3M HONEYCOMB RED REFLECTIVE		A/R	
	8519	DECAL, SLOW MOVING VEHICLE		1	

ONE-YEAR LIMITED WARRANTY

For AMADAS INDUSTRIES Stalk Puller / Chopper

A. General Provisions

The Warranties described below are provided by AMADAS INDUSTRIES ("AMADAS") through its authorized dealers to the original purchaser of each new AMADAS Stalk Puller / Chopper. AMADAS will repair or replace, at its option, any part covered under warranty which is found to be defective in material or workmanship during the applicable period of warranty. This warranty is applicable only to the cost of the part replaced or repaired and does not cover labor costs involved in installing the replaced or repaired defective part.

B. What is Warranted?

All parts of any new AMADAS Stalk Puller / Chopper are warranted for 12 months. The warranty period will begin when the Stalk Puller / Chopper is delivered to the purchaser. AMADAS will repair or replace, at its option, any new part or component under the above warranty, if a defect in material or workmanship appears in such part or component and is reported to AMADAS before the expiration of the applicable equipment warranty.

Used equipment is not warranted by AMADAS unless it is specifically covered by a separate warranty document. The above warranties cover only defective material and workmanship. The warranties do not cover any depreciation or failure caused by normal wear, lack of proper maintenance or use, misuse, lack of proper protection during storage, or accident. The purchaser shall pay all costs of routine maintenance and/or replacement of maintenance and wear items.

C. Unapproved Service or Modification

All Obligations of AMADAS under this warranty are terminated if the Stalk Puller / Chopper is modified or altered in ways not approved by AMADAS.

D. Securing Warranty Service

To secure warranty service, the purchaser must (1) report the product defect and request repair within the applicable warranty period, (2) present evidence of the date of delivery of the Stalk Puller / Chopper, and (3) make the Stalk Puller / Chopper available to an AMADAS authorized dealer within a reasonable period of time.

E. No Dealer Warranty

The selling dealer makes no warranty of his own on any item warranted by AMADAS, and makes no warranty on other items. The dealer has no authority to make any representation or promise on behalf of AMADAS, or to modify the terms or limitations of this warranty in any way.

F. What are your Responsibilities?

- a. Read the operator's manual before operating the equipment.
- b. Perform all necessary maintenance as described in the operator's manual.
- c. Deliver the machine to an AMADAS authorized dealer at your expense during normal working hours for any needed warranty services.
- d. Contact an AMADAS authorized dealer promptly on any claim for warranty service.
- e. Sign the AMADAS machinery delivery form, which will be given to you by the dealer.

G. Disclaimer

There are no warranties that extend beyond the description here. **ANY WARRANTIES OF MERCHANTABILITY AND FITNESS FOR ANY PARTICULAR PURPOSE ARE SPECIFICALLY DISCLAIMED AS ARE ALL OTHER REPRESENTATIONS TO THE PURCHASER.** AMADAS specifically excludes any liability on behalf of the company for any incidental or consequential damages including, but not limited to, crop loss, loss of profits, rental of substitute equipment, or other commercial losses. AMADAS shall not be responsible for expenses or inconveniences that you might incur or experience with respect to the AMADAS Stalk Puller / Chopper, nor shall AMADAS be liable for defects, damage, or failures caused by improper storage, unreasonable use, or abuse, or accident, including the failure to provide reasonable and specified maintenance. This warranty applies only to the original purchaser of the equipment. Because some states do not allow the exclusion of limitations of incidental or consequential damages, the above limitation may not apply to you. This warranty gives you specific legal rights. You may also have other rights, which vary from state to state. Where there is a conflict between a provision of this warranty and the provision of any state, the state legislation prevails.

AMADAS