

# FORM 0374 Seal Kits for Hydraulic Cylinders

If hydraulic cylinder seals start to wear and leakage occurs, seal kits are available for the cylinders installed on Amadas products. When ordering a seal kit, you need to be aware of the following:

- Three different manufacturers provide Amadas with cylinders: US Cylinders, Prince Cylinders, and Georgia Hydraulics Cylinders.
- Cylinders are installed in terms of availability, not by product type.
- An Amadas parts number is assigned to each cylinder for a product, but the number does NOT specify the manufacturer of the product.

Determine how to order a cylinder as follows:

1. To order a cylinder seal kit, first determine the Amadas part number by referring to the list for each brand of cylinder. If you are unable to locate your cylinder on the list, refer to the parts

catalog for your machine. A parts catalog was included with the delivery of your product and they are also available online at [www.amadas.com](http://www.amadas.com).

2. Once you have found the cylinder part number listed under a manufacturer, visually inspect the cylinder to determine if produced by that manufacturer. If the cylinder matches that manufacturing style, continue with Step 3. If not, compare the cylinder to the other manufacturers' cylinder styles.
3. Once you have determined the part number and manufacturer of the cylinder, locate the part number of the seal kit in the far right hand column of the chart for that manufacturer.
4. Place the order for the seal kit as you would for any other Amadas part, making sure to give both the seal kit number AND the manufacturer when you place the order.

## Georgia Hydraulics Cylinders

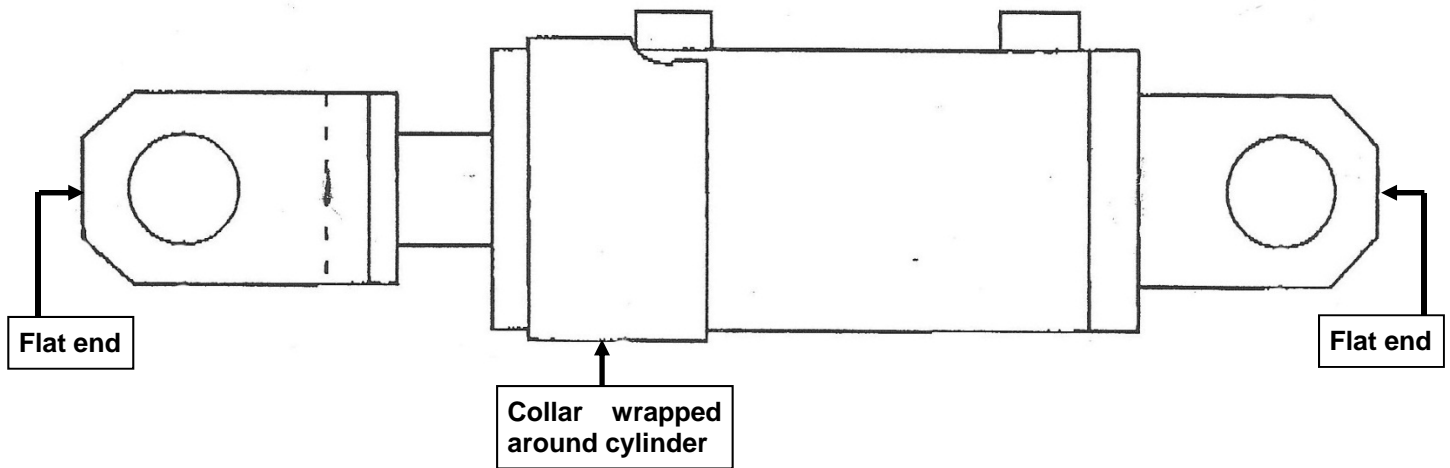

To determine if the cylinder was manufactured by Georgia Cylinders, look for:

- Flat ends
- A distinctive “collar” that wraps around the cylinder (in most applications)
- Installed with either a clip or pin

<b>Amadas Part Number</b>	<b>Cylinder Description</b>	<b>Product Used On As of 11/2011</b>	<b>Amadas Seal Kit Number for Georgia Cylinder</b>
140182	3-1/2" x 48-3/8"	7500 Basket, RMH Lift Mast	140182G
140691	4-1/2" x 72"	ICT 950-1100	140691G
140766	3" and 8" strokes	Long Reach Mower (breakaway)	140766G
14832	3" x 10"	Tongue PT Combine, PT Tongue Lift and Side Shifts, RMH Mast Tilt, Bag Flattener	14832G
14927	4" x 48-3/8"	ICT 950-1100	14927G
14986	2-1/2" x 55"	Palletizer	14986G

## Prince Cylinders

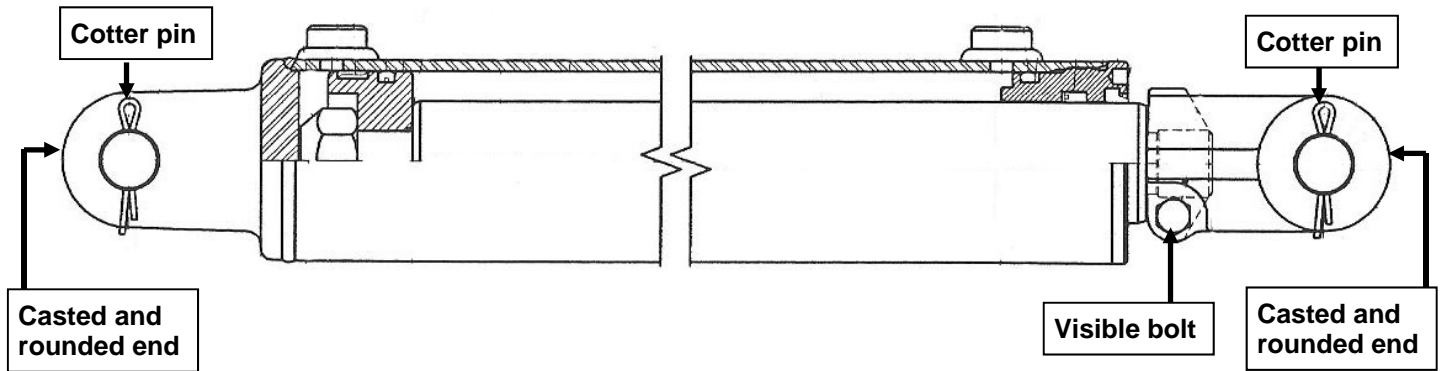

To determine if the cylinder was manufactured by Prince Cylinders, look for:

- Casted ends
- Rounded ends
- Installed with a cotter pin
- A visible bolt as indicated in the drawing above

Amadas Part Number	Cylinder Description	Product Used On As of 11/2011	Amadas Seal Kit Number for Prince Cylinder
140182	3-1/2" x 48-3/8"	7500 Basket; RMH Lift Mast	140182PA
140295	2-1/2" x 20-3/8"	Feeder House; SP 9970	140295PA
140569	1-1/2" x 6"	SP VS Gearbox (w/spring)	140569PA
140635	2-1/2" x 30"	SP and PT Conveyor Swing	140635PA
140691*	4-1/2" x 72"	ICT 950-1100	140691PA
140766	3" and 8" strokes	Long Reach Mower (breakaway)	140766PA
140989	4" x 20"	Long Reach Mower	140989PA
14831	3" x 35-1/2"	6500 Basket Irrigator Legs	14831PA
14832	3" x 10"	Tongue PT Combine, PT Tongue Lift and Side Shifts, RMH Mast Tilt, Bag Flattener	14832PA
14927	4" x 48-3/8"	ICT 950-1100	14927PA
14986	2-1/2" x 55"	Palletizer	14986PA

\*Cylinder # 140691 manufactured by Prince has unique fittings and is easily recognizable:

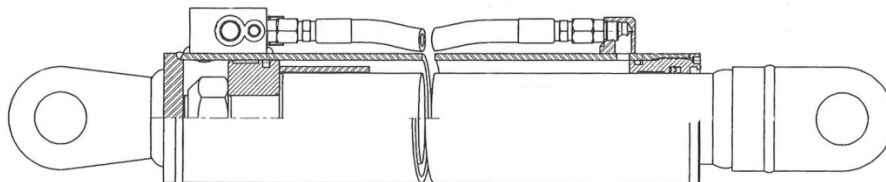

## U.S. Cylinders

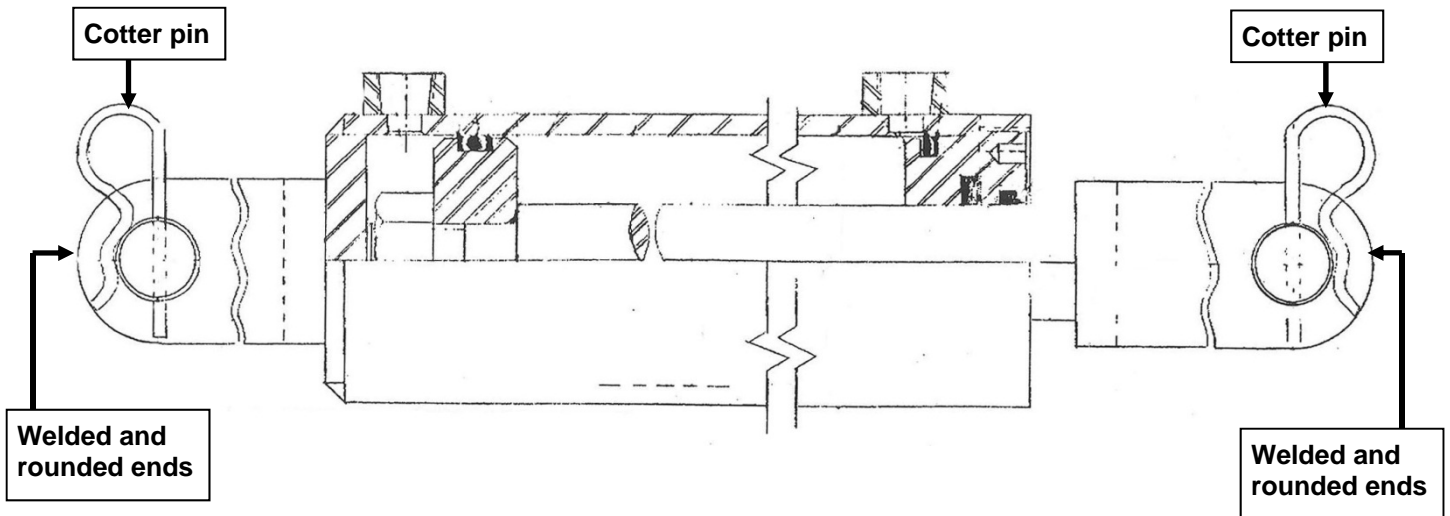

To determine if the cylinder was manufactured by U.S. Cylinders, look for:

- Welded ends
- Rounded ends
- Installed with a clip

Amadas Part Number	Cylinder Description	Product Used On As of 11/2011	Amadas Seal Kit Number for U.S. Cylinder
140182	3-1/2" x 48-3/8"	7500 Basket; RMH Mast Lift	140182A
140295	2-1/2" x 20-3/8"	Feeder House; SP 9970	140295A
140569	1-1/2" x 6"	SP VS Gearbox (w/spring)	140569A
140635	2-1/2" x 30"	SP and PT Conveyor Swing	140635A
140691	4-1/2" x 72"	ICT 950-1100	140691A
140766	3" and 8" strokes	Long Reach Mower (breakaway)	140766A
140989	4" x 20"	Long Reach Mower	140989A
14831	3" x 35-1/2"	6500 Basket Irrigator Legs	14831A
14832	3" x 10"	Tongue PT Combine, PT Tongue Lift and Side Shifts, RMH Mast Tilt, Bag Flattener	14832A
14927	4" x 48-3/8"	ICT 950-1100	14927A
14986	2-1/2" x 55"	Palletizer	14986A