

BF01 BULK FEEDER

1st EDITION

CAT135

BEGINNING SERIAL #A33600

Owner's Name _____
Dealer's Name _____
Serial Number _____ **Model No.** _____
Date Purchased _____

TABLE OF CONTENTS

CAT135
1st Edition
January 1, 1997

BF01 BULK FEEDER

Section	Page
1 Main Frame, Panels, Shields Section.....	3
2 Drive Assembly Section.....	5
3 Inverter Drive Section - Optional.....	7
4 Batterboard Section.....	9
5 Polyethylene Slide Kits Section - BF013014S.....	11
6 Polyethylene Slide Kit Section - BF013014V.....	13
7 Feed Gate Assembly - Optional (BF013014V).....	15
8 Decals.....	17
Numerical Parts Index.....	18
Warranty	

NOTES

The Terms "Left" and "Right" used in the description of parts are determined by facing the direction of flow of material through the machine.

"A/R" found in the "No. Req'd" column denotes "As Required".

"OPT" found in the "No., Req'd" column denotes "Optional".

1100 Holland Road Suffolk, VA 23434 U.S.A.
(757) 539-0231 / Fax - (757) 934-3264

1701 S. Slappey Blvd./P.O. Box 3687 Albany, GA 31706
(912) 439-2217 / Fax (912) 439-9343

AMADAS
INDUSTRIES

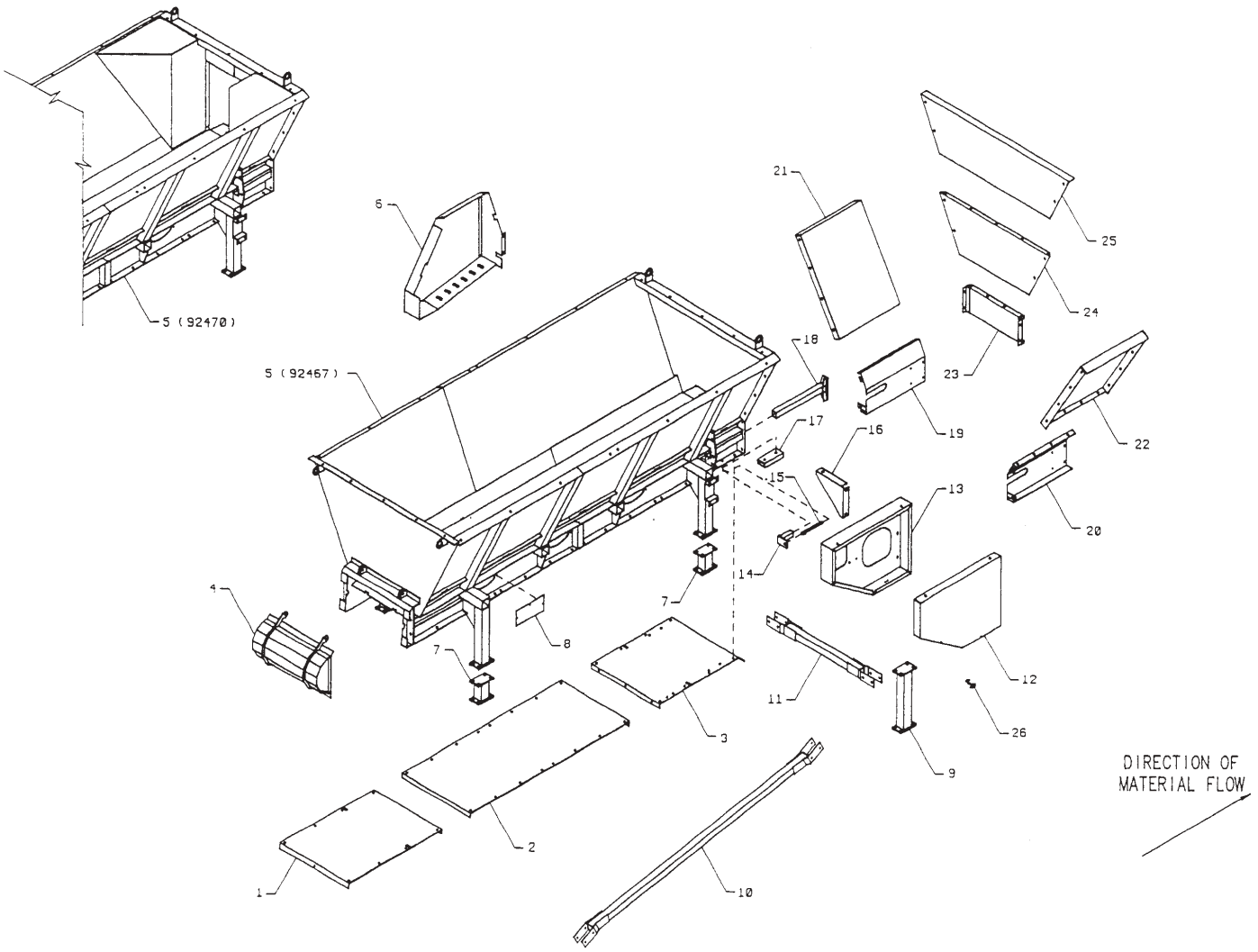

1. MAIN FRAME, PANELS, SHIELDS SECTION

NO.	PART NO.	KEYWORD	DESCRIPTION	NO. REQ'D
1	123781	PANEL	FLOOR; INFEED	1
2	123782	PANEL	FLOOR; CENTER	1
3	123783	PANEL	FLOOR; DISCHARGE	1
4	61265	DOOR	RECIRCULATION CHAMBER	1
5	92467	FRAME	BF013014S FEEDER; MAIN	OPT
--	92470	FRAME	BF013014V FEEDER; MAIN	OPT
6	123792	SHIELD	CHAIN DRIVE; LT (POSITION A; RT TO LT)	OPT
--	124161	SHIELD	CHAIN DRIVE;RT (POSITION B; LT TO RT) ..	OPT
7	92472	LEG	8.1/2" EXTENSION.....70082	OPT
--	92473	LEG	14.1/2" EXTENSION.....70083	OPT
8	123765	COVER	LOWER SIDE PANEL	6
9	92474	LEG	26.5 EXTENSION.....70084	OPT
--	92477	LEG	44.5 EXTENSION.....70085	OPT
10	92694	BRACE	LEG EXTENSION; DIAGONAL	OPT
11	92695	BRACE	LEG EXTENSION; HORIZONTAL	OPT
12	123791	SHIELD	BELT; FRONT RT (POSITION A; RT TO LT) ..	OPT
--	124162	SHIELD	BELT; FRONT LT (POSITION B; LT TO RT) ..	OPT
13	123790	SHIELD	BELT; REAR RT (POSITION A; RT TO LT) ...	OPT
--	124164	SHIELD	BELT;REAR LT (POSITION B; LT TO RT)	OPT
14	61264	TAKE-UP	TENSIONER	2
15	1732	ROD	TAKE-UP	2
16	123789	BRACE	SHIELD; RT (POSITION A; RT TO LT)	OPT
--	124163	BRACE	SHIELD; LT (POSITION B; LT TO RT)	OPT
17	92466	MOUNT	BEARING	2
18	61263	TENSIONER	BEARING	2
19	123773	EXTENSION	LOWER LEFT	1
20	123772	EXTENSION	LOWER RIGHT	1
21	123775	EXTENSION	BULK FEEDER; LEFT	1
22	123774	EXTENSION	BULKFEEDER; RIGHT	1
23	123776	END	EXTENSION	1
24	123777	PANEL	EXTENSION; END	1
25	123778	PANEL	EXTENSION; END	1
26	7024	HOOK	SPRING LOADED; 90 DEGREE	2

2. DRIVE ASSEMBLY SECTION

NO.	PART NO.	KEYWORD	DESCRIPTION	NO. REQ'D
1	10351	IDLER	INFEED FLIGHT CHAIN	1
2	3119	BEARING	1-15/16 PILLOW BLOCK	4
3	3090	COLLAR	1-15/16 ECCENTRIC LOCKING	A/R
4	4533	CHAIN	FLIGHT	7
5	G220088	NUT	1-8 USS	1
6	61266	WASHER	IDLER PIVOT	2
7	61267	PIVOT	IDLER	1
8	G271891	SCREW	1-8X4-1/2 USS	1
9	61268	SPACER	IDLER	2
10	51040	IDLER	CHAIN	2
11	7451	SPRING	EXTENSION	1
12	1736	ROD	ADJUSTING	1
13	5721	SPROCKET	80B12 F 1-15/16 BORE	1
14	10586	SHAFT	JACK	1
15	20437	BUSHING	1-15/16" TWIN TAPERED	1
16	5052	SHEAVE	1B20.0-PD QD-SK	1
17	5652	BUSHING	1-1/4 SK	1
18	15162	MOTOR	3H/3P/460/1800/182T/TEFC	1
19	5416	SHEAVE	HI-LO66TBRTYPE416SS 1-1/8.....70071	OPT
--	51072	SHEAVE	1B46SDS.....70076, 70074, 70075	OPT
20	92468	MOUNT	MOTOR	1
21	3125	COLLAR	2-7/16 ECCENTRIC LOCKING	A/R
22	3124	BEARING	2-7/16 PILLOW BLOCK	2
23	5687	SPROCKET	WH-78; 9 TOOTH W/HUB	2
24	5663	BUSHING	Q1 2-7/16	3
25	80Q60	SPROCKET	80Q60	1
26	5075	BUSHING	QD-SDS 1-1/8.....(USE W/51072)	OPT
27	B88	BELT	B88 (POSITION A; RIGHT TO LEFT)	OPT
--	B91	BELT	B91 (POSITION B; LEFT TO RIGHT)	OPT
28	4365-95	CHAIN	NO.80, 95 PITCHES + CONNECTOR + OFFSET	1
29	11286	GEARBOX	25:1 SHAFT MOUNTED	1
30	10352	SHAFT	FRONT DRIVE	1
31	11286A	ASSEMBLY	TURNBUCKLE W/MOUNTS	1
32	11341	GEARBOX	15:1 TORQUE ARM; HXT315A	OPT
33	140228	MOTOR	HYDRAULIC; B30	OPT

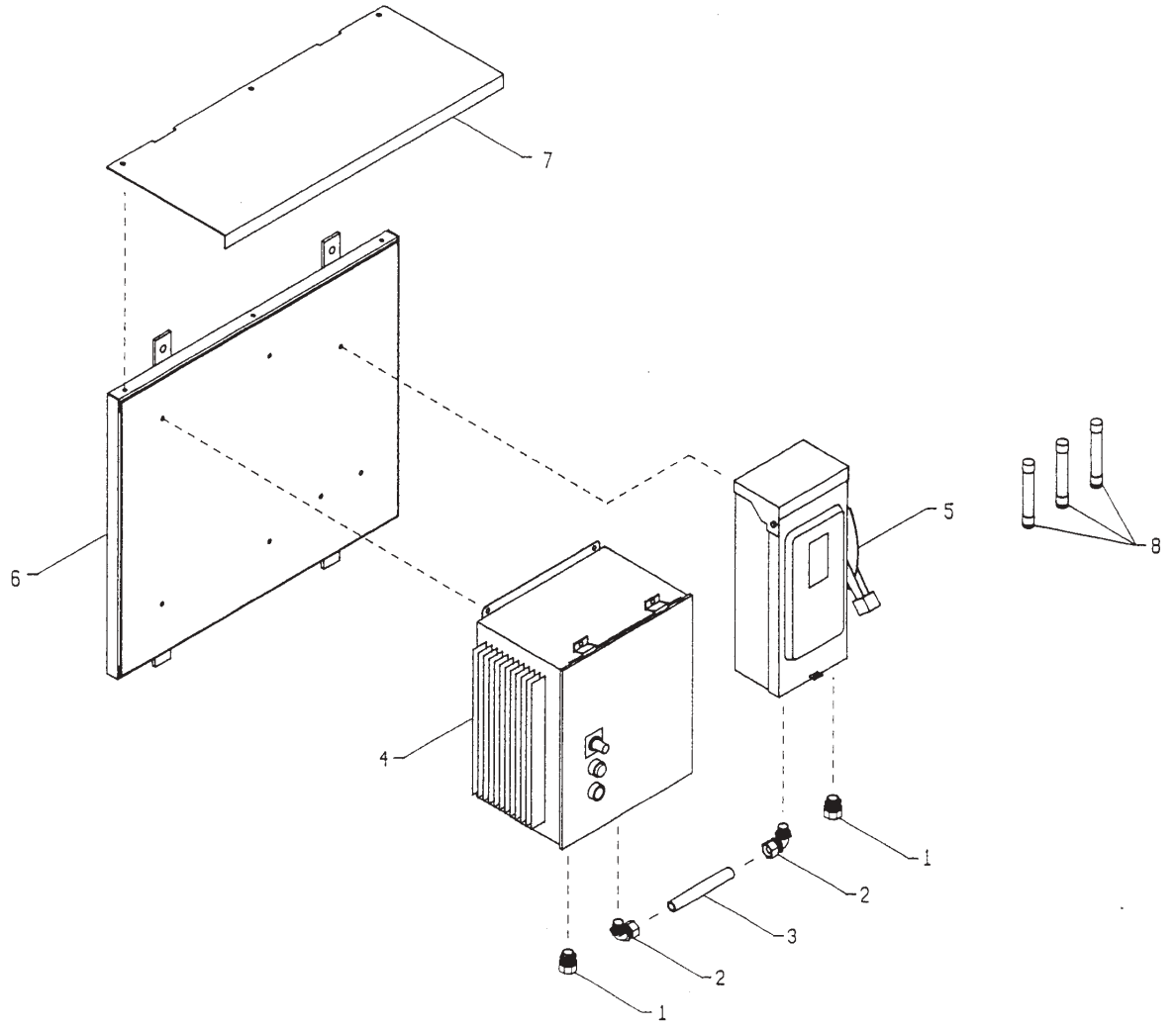

3. INVERTER DRIVE SECTION - OPTIONAL

NO.	PART NO.	KEYWORD	DESCRIPTION	NO. REQ'D
1	15094	CONNECTOR	3/8 STRAIGHT LIQUID TIGHT	2
2	15096	CONNECTOR	3/8 90 DEG. LIQUID TIGHT	2
3	15089	CONDUIT	3/8 LIQUATITE, 5.1/2" LONG	1
4	15765	INVERTER	V14030C NEMA4 ENCLOSURE.....US	1
--	15795	INVERTER	L15030C NEMA4 ENCLOSURE.....CANADA	1
--	15884	INVERTER	Q24003C NEMA4 ENCLOSURE.....EUROPE	1
5	15104	SWITCH	SAFETY 30 AMP 3PHASE	1
6	91622	PANEL	INVERTER/SWITCH	1
7	122962	HOOD	INVERTER/SWITCH	1
8	15796	FUSE	FLSR-15	3

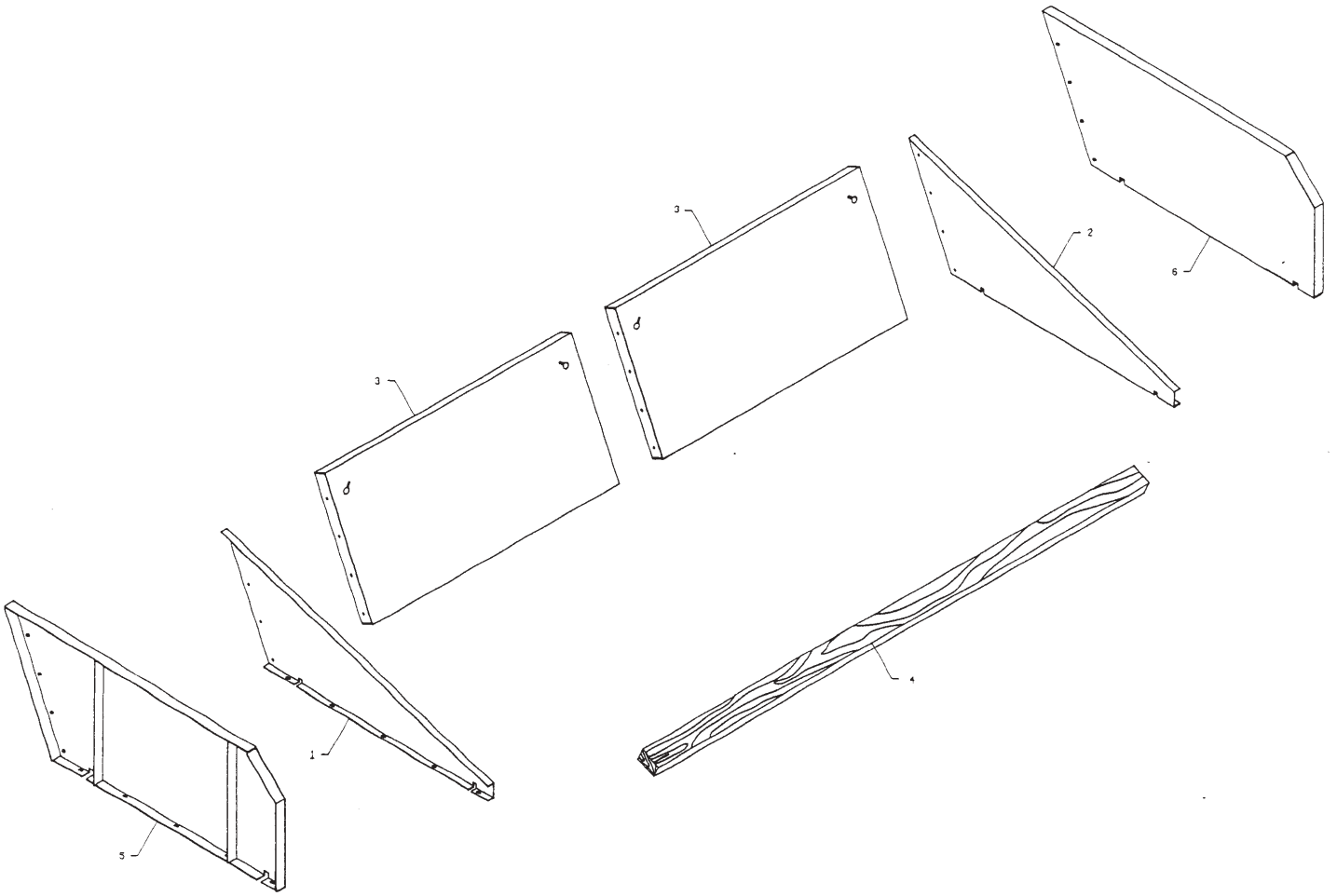

4. BATTERBOARD SECTION

NO.	PART NO.	KEYWORD	DESCRIPTION	NO. REQ'D
1	123750	PANEL	BOARD; INFEEED END	1
2	123751	PANEL	BOARD; DISCHARGE END	1
3	123793	PANEL	BATTER BOARD	2
4	13660	BOARD	LIP	1
5	92705	EXTENSION	BULK FEEDER; LEFT	OPT
6	92706	EXTENSION	BULK FEEDER; RIGHT	OPT

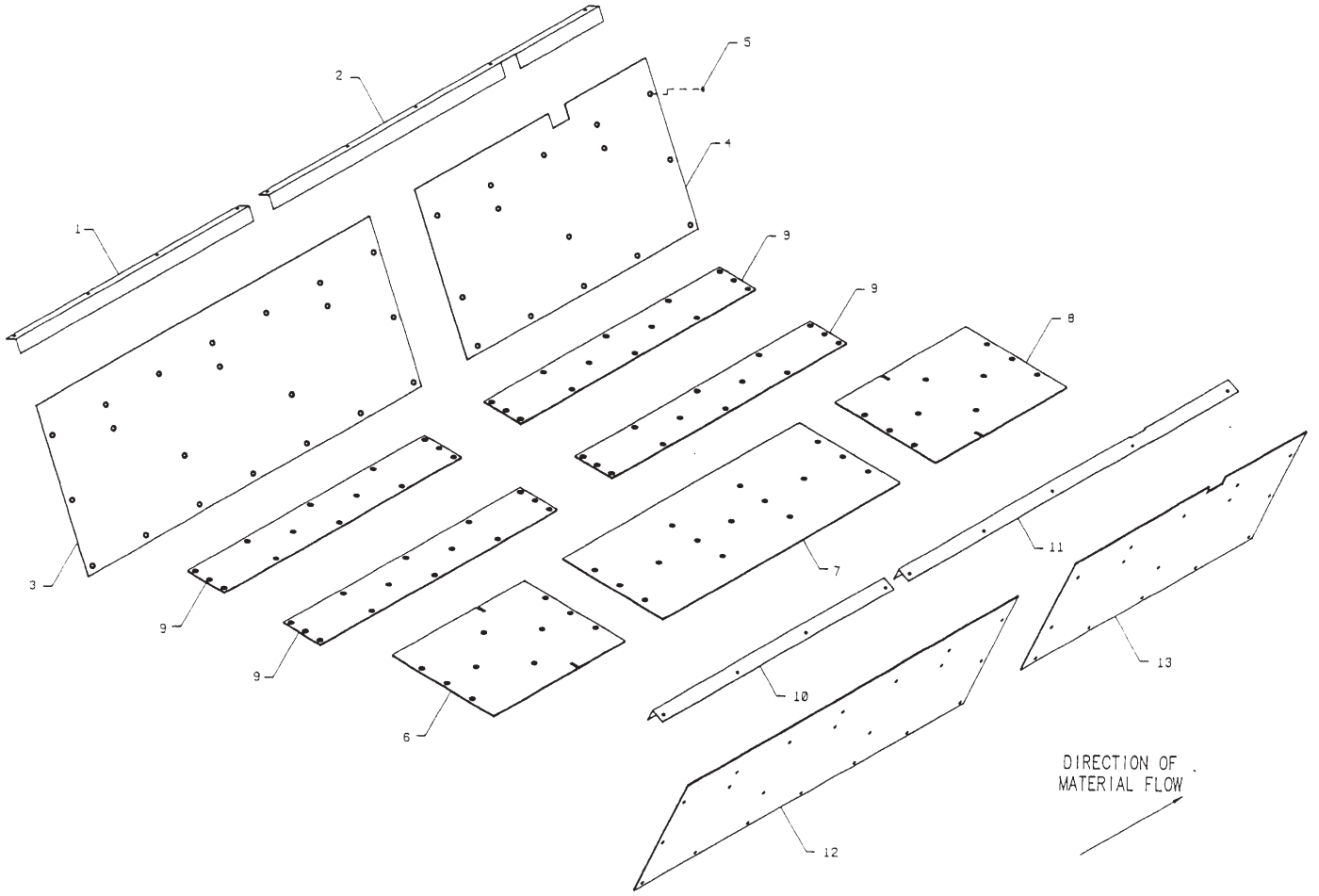

5. POLYETHYLENE SLIDE KITS SECTION - BF013014S

NO.	PART NO.	KEYWORD	DESCRIPTION	NO. REQ'D
1	123794	CLAMP	POLY SIDE; LEFT INFEED	1
2	123796	CLAMP	POLY SIDE; LEFT DISCHARGE	1
3	13662	PANEL	POLY SIDE; LEFT INFEED	1
4	13664	PANEL	POLY SIDE; LEFT DISCHARGE	1
5	1573	WASHER	WELD 1.3/8 X 3/8 X 14 GA.....(70077)	74
--	1573	WASHER	WELD 1.3/8 X 3/8 X 14 GA.....(70079)	36
--	1573	WASHER	WELD 1.3/8 X 3/8 X 14 GA.....(70078)	56
6	13669	PANEL	POLY; RECIRCULATION PATH	1
7	13667	PANEL	POLY; RECIRCULATION PATH	1
8	13668	PANEL	POLY; RECIRCULATION PATH	1
9	13666	PANEL	POLY FLOOR	4
10	123795	CLAMP	POLY SIDE; RIGHT INFEED	1
11	123797	CLAMP	POLY SIDE; RIGHT DISCHARGE	1
12	13663	PANEL	POLY SIDE; RIGHT INFEED	1
13	13665	PANEL	POLY SIDE; RIGHT DISCHARGE	1

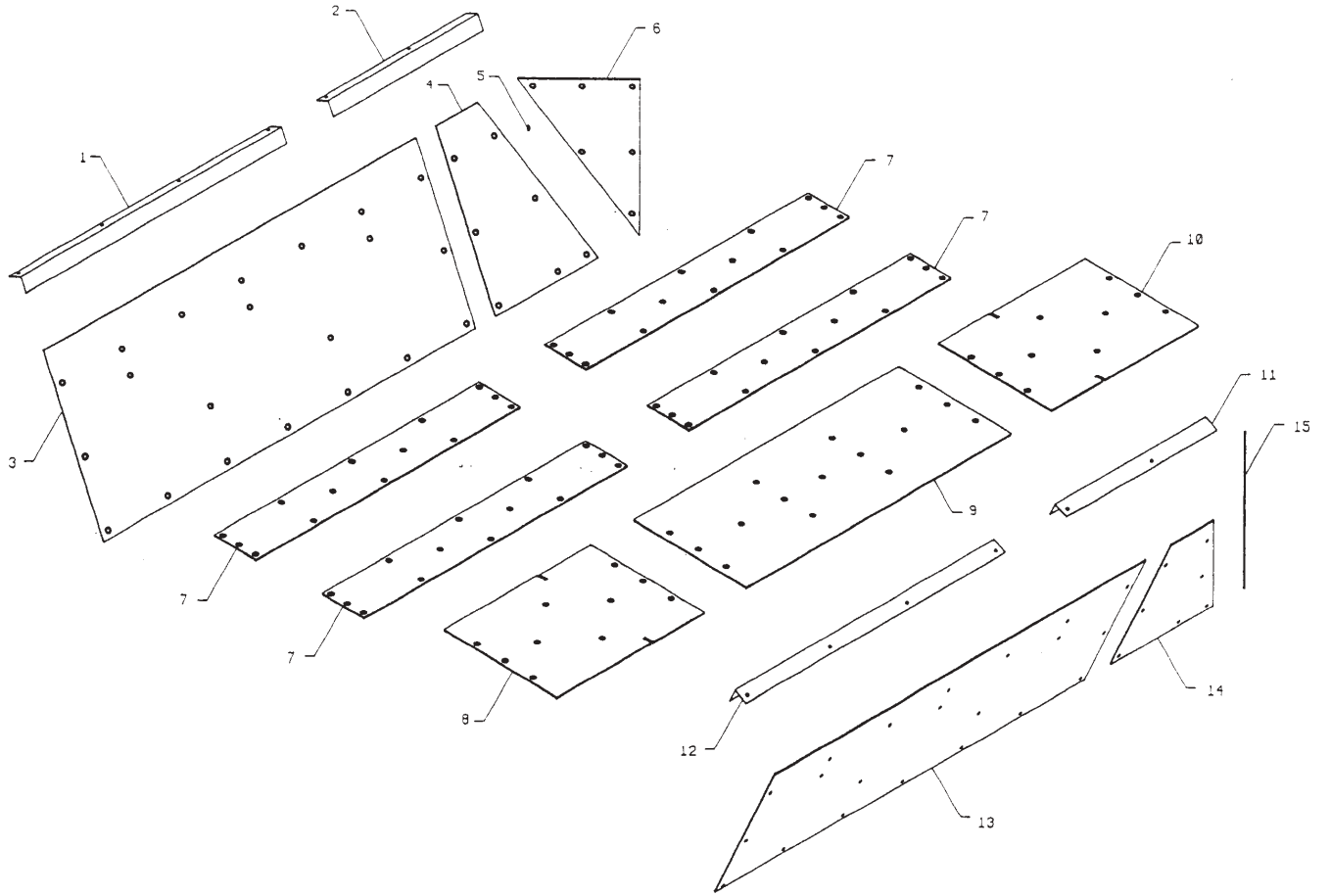

6. POLYETHYLENE SLIDE KIT SECTION - BF013014V

NO.	PART NO.	KEYWORD	DESCRIPTION	NO. REQ'D
1	123794	CLAMP	POLY SIDE; LEFT INFEEED	1
2	123798	CLAMP	POLY.SIDE; LEFT DISCHARGE	1
3	13662	PANEL	POLY SIDE; LEFT INFEEED	1
4	13670	PANEL	POLY SIDE; LEFT INFEEED	1
5	1573	WASHER	WELD 1.3/8 X 3/8 X 14 GA	68
6	13672	PANEL	POLY; LEFT METERED SIDE	1
7	13666	PANEL	POLY FLOOR	4
8	13669	PANEL	POLY; RECIRCULATION PATH	1
9	13667	PANEL	POLY; RECIRCULATION PATH	1
10	13668	PANEL	POLY; RECIRCULATION PATH	1
11	123799	CLAMP	POLY.SIDE; RIGHT DISCHARGE	1
12	123795	CLAMP	POLY SIDE; RIGHT INFEEED	1
13	13663	PANEL	POLY SIDE; RIGHT INFEEED	1
14	13671	PANEL	POLY SIDE; RIGHT INFEEED	1
15	13673	PANEL	POLY; RIGHT METERED SIDE	1

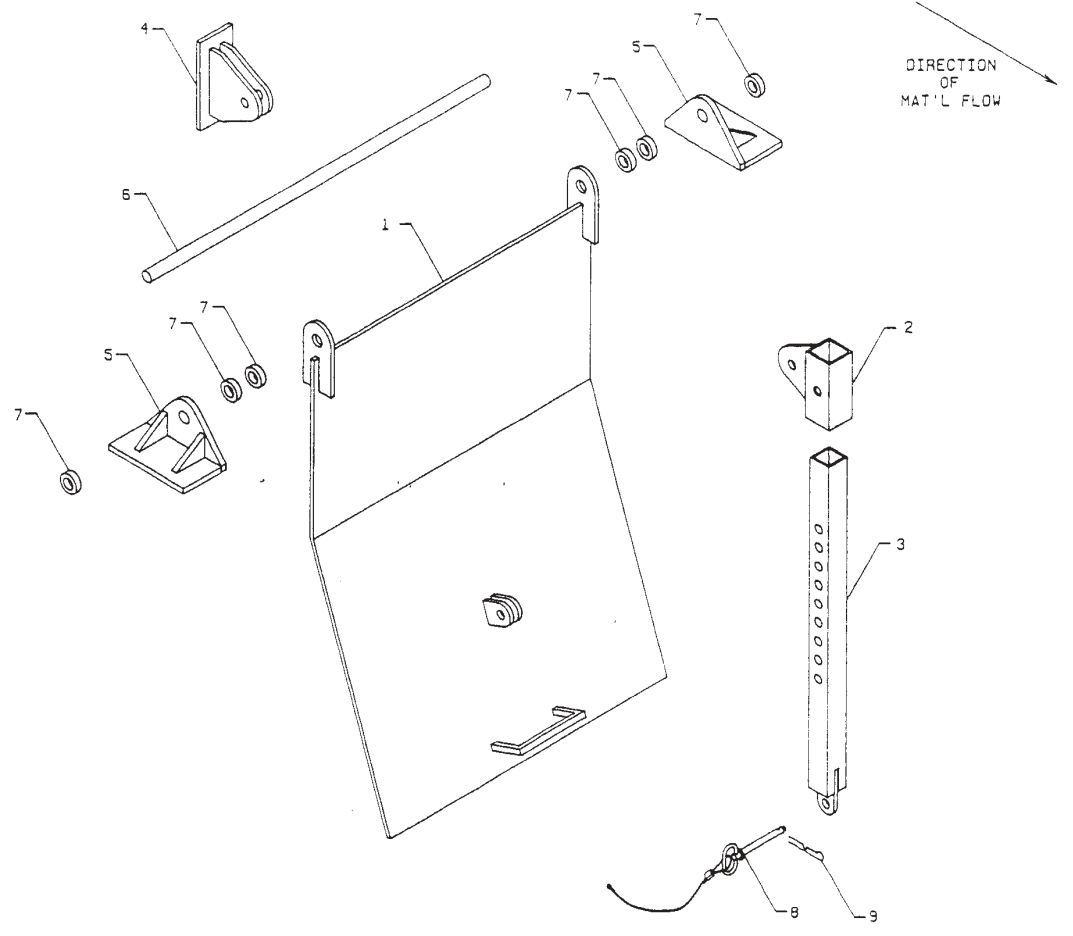

7. FEED GATE ASSEMBLY - OPTIONAL (BF013014V)

NO.	PART NO.	KEYWORD	DESCRIPTION	NO. REQ'D
--	7443	KIT	FEED GATE ASSEMBLY	
1	61124	GATE	FEED DOOR	1
2	61121	ADJUSTER	FEED GATE MOVEABLE LUG	1
3	61120	ADJUSTER	FEED GATE	1
4	61125	MOUNT	STATIONARY GATE DOOR	1
5	61126	MOUNT	GATE DOOR PIVOT	2
6	10551	SHAFT	FEED GATE PIVOT	1
7	3184	COLLAR	1" SPLIT RING	6
8	S2056	ASSEMBLY	PIN CABLE	1
9	2196	PIN	PLATED HAIR COTTOR	1

DANGER

**Machinery may start
without warning.
Operated from
remote location.**

8180

1

! CAUTION

Do Not Operate this machine until you have read and understand the operators manual. If you do not have a copy of the operators manual contact your dealer or our factory immediately.

Amadas Industries
1100 Holland Rd./Suffolk, VA 23434
804-539-0231
or
1701 S. Slappey Blvd./Albany, GA
31706 - 912-439-2217

8191

2

CAUTION

- 1) Keep all shields in place while Machinery is in Operation.
- 2) Disengage Power before proceeding to adjust, lubricate, clean, unclog or otherwise work on machine unless unless specifically recommended in the Operator's Manual.
- 3) Wait for all motion to stop before serving this machine
- 4) Keep Hands, Feet, and Clothing away from moving parts.
- 5) Keep off Equipment unless seat or platform for operation is provided.
- 6) Keep all others off.
- 7) Make certain everyone is clear of machine before starting.

8168

3

CAUTION

**Do Not Operate unless
all Safety Shields &
Guards are in place.**

8188

4

DANGER

**HIGH
VOLTAGE**

5

8. DECALS

NO.	PART NO.	KEYWORD	DESCRIPTION	NO. REQ'D
1	8180	DECAL	"DANGER"; REMOTE OPERATION	2
2	8191	DECAL	CAUTION: READ OP.MANUAL	1
3	8190	DECAL	"CAUTION" (LIST)	1
4	8188	DECAL	"CAUTION": SHIELDS	2
5	8272	DECAL	DANGER:HIGH VOLTAGE.....INVERTER DRIVE	1

NOTE: THE FOLLOWING DECALS ARE USED BUT
ARE NOT SHOWN.

--	8343	DECAL	AMADAS "AMERICAN MADE"	1
--	80030	DECAL	"AMADAS"; 10"	2
--	8398	DECAL	AMADAS; 36" GRAY	1

REFER TO OPERATOR'S MANUAL FOR LOCATION
OF DECALS & ADDITIONAL SAFETY
INFORMATION.

NUMERICAL PARTS INDEX

PART NO.	PAGE	PART NO.	PAGE	PART NO.	PAGE
B88	5	15094	7	92470	3
B91	5	15096	7	92472	3
G220088	5	15104	7	92473	3
G271891	5	15162	5	92474	3
S2056	15	1573	11, 13	92477	3
10351	5	15765	7	92694	3
10352	5	15795	7	92695	3
10551	15	15796	7	92705	9
10586	5	15884	7	92706	9
11286	5	1732	3		
11286A	5	1736	5		
11341	5	20437	5		
122962	7	2196	15		
123750	9	3090	5		
123751	9	3119	5		
123765	3	3124	5		
123772	3	3125	5		
123773	3	3184	15		
123774	3	4365-95	5		
123775	3	4533	5		
123776	3	5052	5		
123777	3	5075	5		
123778	3	51040	5		
123781	3	51072	5		
123782	3	5416	5		
123783	3	5652	5		
123789	3	5663	5		
123790	3	5687	5		
123791	3	5721	5		
123792	3	61120	15		
123793	9	61121	15		
123794	11, 13	61124	15		
123795	11, 13	61125	15		
123796	11	61126	15		
123797	11	61263	3		
123798	13	61264	3		
123799	13	61265	3		
124161	3	61266	5		
124162	3	61267	5		
124163	3	61268	5		
124164	3	7024	3		
13660	9	7443	15		
13662	11, 13	7451	5		
13663	11, 13	80Q60	5		
13664	11	80030	17		
13665	11	8180	17		
13666	11, 13	8188	17		
13667	11, 13	8190	17		
13668	11, 13	8191	17		
13669	11, 13	8272	17		
13670	13	8343	17		
13671	13	8398	17		
13672	13	91622	7		
13673	13	92466	3		
140228	5	92467	3		
15089	7	92468	5		

WARRANTY

For AMADAS INDUSTRIES Industrial Machinery

A. General Provisions

AMADAS INDUSTRIES ("Company") warrants that each machine manufactured by it and sold under its trademark shall be free from defects in material and workmanship. The company's sole obligation under this warranty shall be limited to making good, F.O.B. Company factory, any part of its product which under normal and proper use and maintenance proves defective in material and workmanship within six months after delivery to the Buyer provided that notice of such defect and satisfactory proof thereof is promptly given by the Buyer to the Company, with transportation charges prepaid, and Company's examination proves such part to have been defective.

This warranty does not apply in respect to damage to any product or accessory or attachment thereof caused by overloading or other misuse, neglect or accident nor does this warranty apply to any product, or accessory or attachment thereof which shall have been repaired or altered by other than the Company which, in the sole judgement of the Company affects the performance, stability or purpose for which it was manufactured.

With respect to tires, engines, or other trade accessories, the Company makes no warranty whatsoever and the buyer shall rely solely upon the existing warranties, if any, of the respective manufacturers thereof.

B. Unapproved Service or Modification

All obligations of AMADAS INDUSTRIES under this warranty are terminated if the machinery is modified or altered in ways not approved by AMADAS INDUSTRIES

C. Owner's Responsibilities

- a. Read the operator's manual before operating the machinery.
- b. Perform all necessary maintenance as described in the operators's manual.
- c. Contact AMADAS INDUSTRIES promptly on any warranty claim.
- d. Sign the AMADAS INDUSTRIES machine delivery form and return promptly as this validates the warranty.

D. Disclaimer

There are no warranties that extend beyond the description here. **ANY WARRANTIES OF MERCHANTABILITY AND FITNESS FOR ANY PARTICULAR PURPOSE ARE SPECIFICALLY DISCLAIMED AS ARE ALL OTHER REPRESENTATIONS TO THE PURCHASER.** AMADAS INDUSTRIES specifically excludes any liability on behalf of the Company for any incidental or consequential damages including, but not limited to loss of profits, rental of substitute equipment, or other commercial losses. AMADAS INDUSTRIES shall not be responsible for expenses or inconvenience that you might incur or experience with respect to any AMADAS INDUSTRIES Industrial Machinery, nor shall AMADAS INDUSTRIES be liable for defects, damage, or failure caused by improper storage, unreasonable use, or abuse, or accident, including the failure to provide reasonable and specified maintenance. This warranty applies only to the original purchaser of the machinery. Because some states do not allow the exclusion of limitation of incidental or consequential damages, the above limitation may not apply to you. This warranty gives you specific legal rights. You may also have other rights, which vary from state to state. Where there is a conflict between a provision of this warranty and the provision of any state, the state legislation prevails.

A M A D A S
INDUSTRIES